

SIP Series

SIP Reed Relay

Features

- Epoxy molded, 4pin single-in-line packages.
- Can be immersed during board cleaning operations.
- High isolation between input and output.
- High density board mounting.
- Diode and magnetic shield available.
- UL recognized.

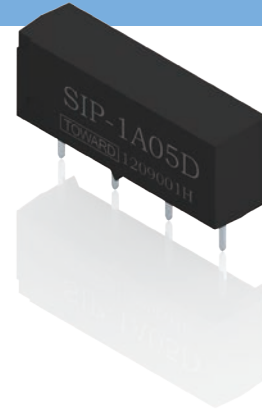

Order Code

SIP- XX-XX X X X
 a b c d e

a : Contact Form : 1A=1 Form A, 1B=1 Form B
 b : Nominal Coil Voltage : 05=5V, 12=12V, 24=24V
 c : Nil=Standard Type, D=Diode, S=Magnetic Shield,
 N=Diode+Magnetic Shield
 d : Special code : Nil=Standard Type, U=High-Sensitivity Type
 e : Special code : Nil=Standard Type, Y or C=ATE Grade

Coil Data-Standard Type 1 Form A (at 20°C)

Nominal Voltage DC $\pm 10\%$ [V]	Coil Resistance $\pm 10\%$ (ohm)		Max. Operate Voltage (VDC)	Min. Release Voltage (VDC)	Max. Allowable Voltage (VDC)
	Standard	High - sensitivity			
5	500	1000	3.75	0.6	10
12	1000	2000	9	1	20
24	2000	--	18	2	32

Coil Data-Standard Type 1 Form B (at 20°C)

Nominal Voltage DC $\pm 10\%$ [V]	Coil Resistance $\pm 10\%$ [ohm]	Nominal Input Power	Max. Operate Voltage (VDC)	Min. Release Voltage (VDC)	Max. Allowable Voltage (VDC)
5	500	50mW	3.75	0.6	6
12	1000	144mW	9	1	14.5
24	2150	268mW	18	2	29

Contact Rating

Part Number	SIP		SIP-Y		SIP-C	
	1FormA	1FormB	1FormA	1FormB	1FormA	1FormB
Max.Switching Power	10W		10W		10W(5V) 15W(12V)	10W
Max.Switching Voltage	100VDC or Peak AC		100VDC or Peak AC		200VDC or 140AC	
Max.Switching Current	0.5A		0.5A		0.5A	
Max.Carry Current	1.0A		1.0A		1.75A	



Specification

Part Number	SIP	SIP-Y	SIP-C
Contact Resistance	150mohm	150mohm	150mohm
Operate Time (Incl.bounce)	1.0mS	1.0mS	1.0mS
Release Time	0.5mS	0.5mS	0.5mS
Insulation Resistance	10 ¹⁰ ohm (100VDC)	10 ¹⁰ ohm (100VDC)	10 ¹⁰ ohm (100VDC)
Dielectric Strength	Between Open Contacts 200VDC	Between Open Contacts 200VDC	Between Open Contacts 250VDC
	Between Coil to Contacts 1500VDC	Between Coil to Contacts 1500VDC	Between Coil to Contacts 1500VDC
Capacitance(between open contacts)	1.0pF	0.3pF	1.4pF
Vibration	20G(10-2KHz)		
Shock Resistance	30G(11ms, 1/2sin Wave)		
Operating Temperature	-40°C ~ +80°C		
Life Expectancy of Electrical	1X10 ⁸ ops(10VDC,10mA)	5X10 ⁷ ops (10VDC, 10mA)	1X10 ⁸ ops (5VDC, 100mA)
			1X10 ⁹ ops(1.0VDC,10mA)

Dimensions (Unit : mm)

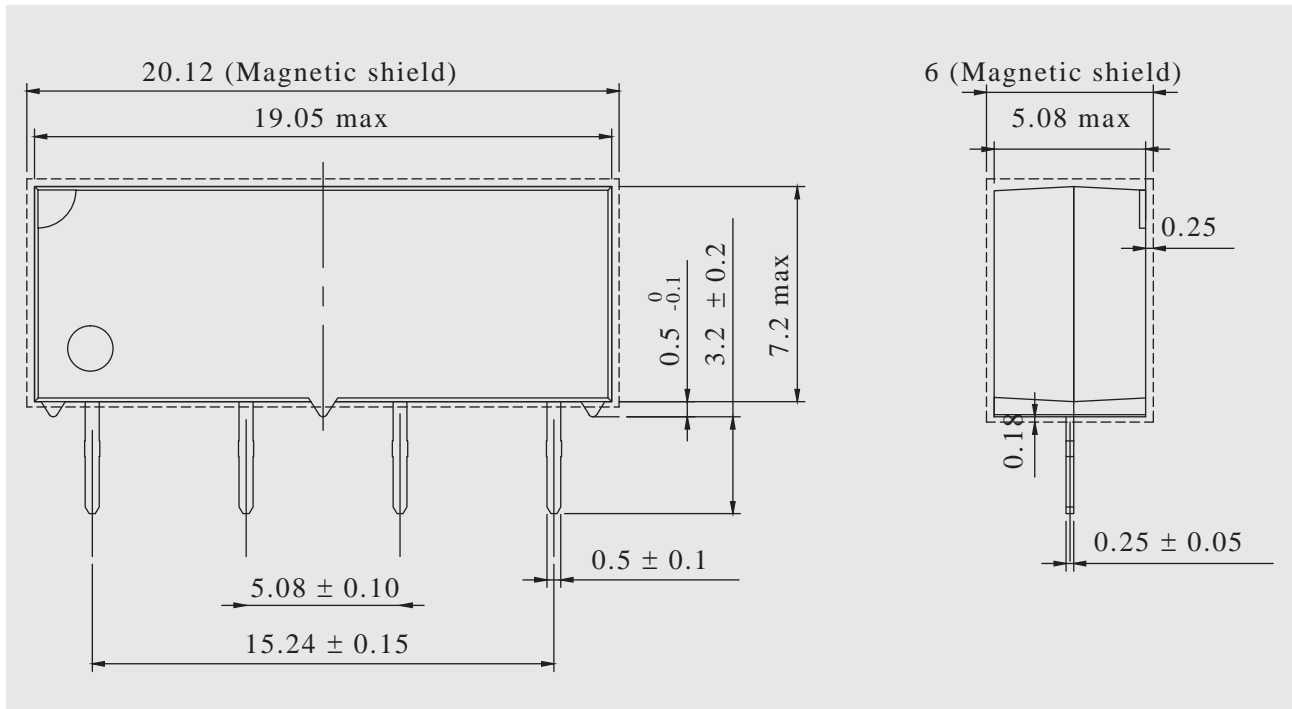

Wiring Diagrams (Bottom View)

