

TAPA

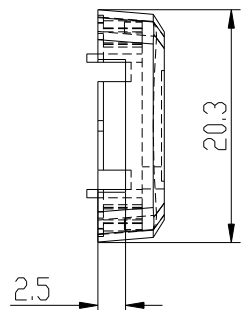

CONECTOR USB

TAPA

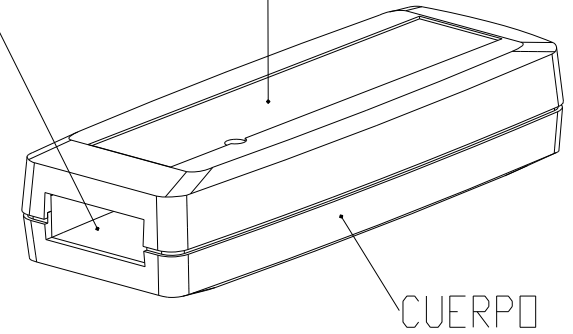

CUERPO

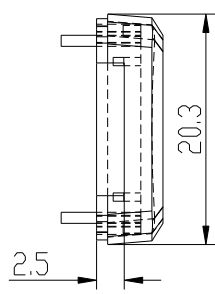
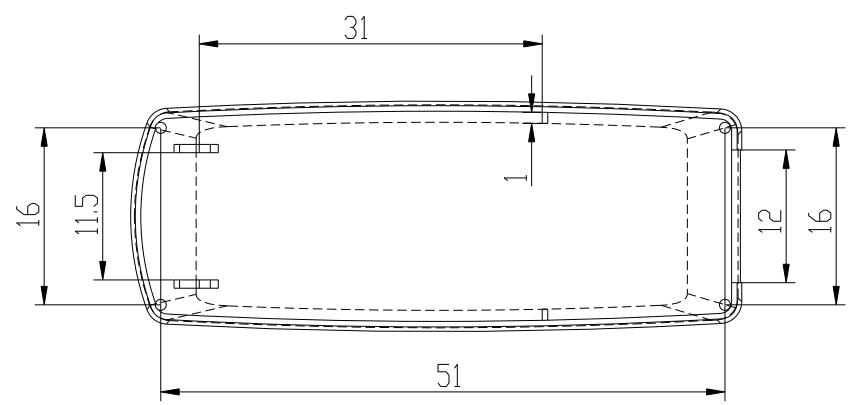
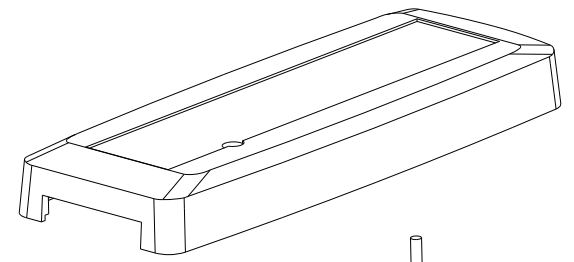
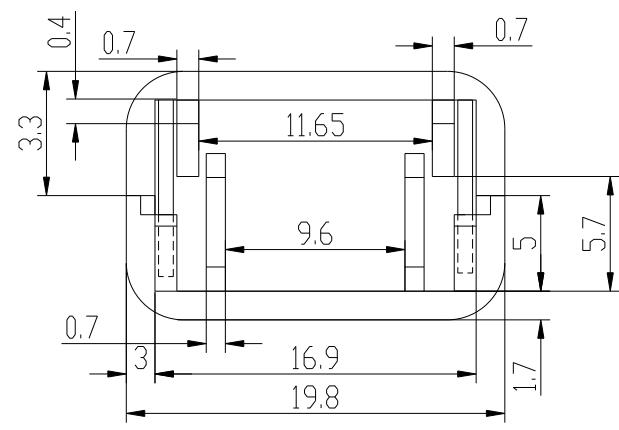
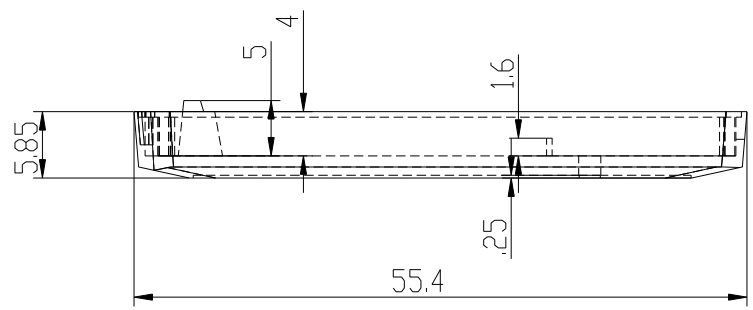

CUERPO

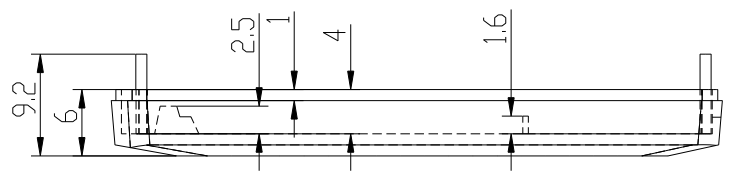
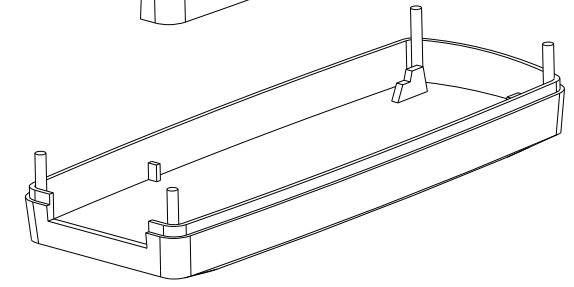

Referencia Electrónica Embajadores: CJPP97x

		Proprietary and confidential of Supertronic		
Plano		Formato DIN A4		
Dibujado	D.R.	Fecha 2007	Peso (gr) 5.4	Dimensiones 55.4x18.5x10
Revisado	J.R.	Fecha 2008	Escala 1/1	Material ABS
⊕	□	Código	Dimensions are in millimeters Tolerance ±0.2mm	
Referencia cliente		Modelo PP97		