

TAPA

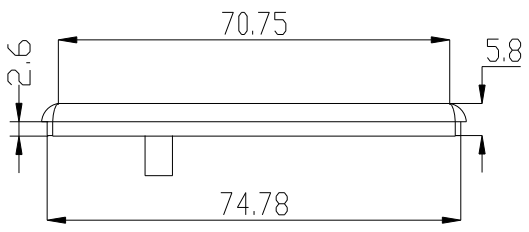
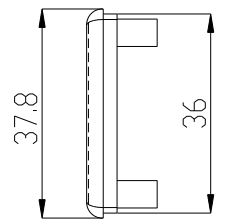
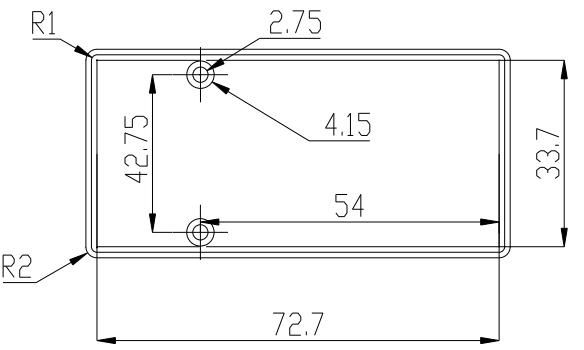
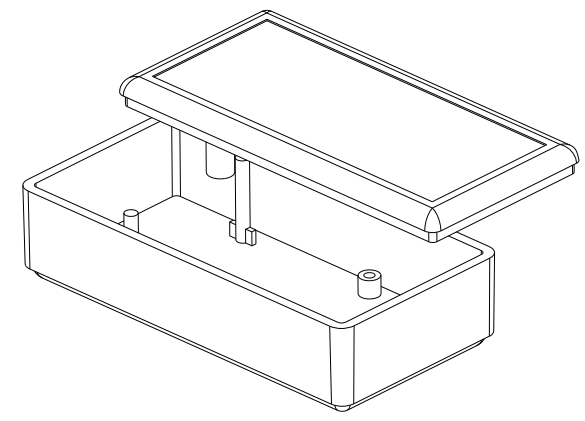
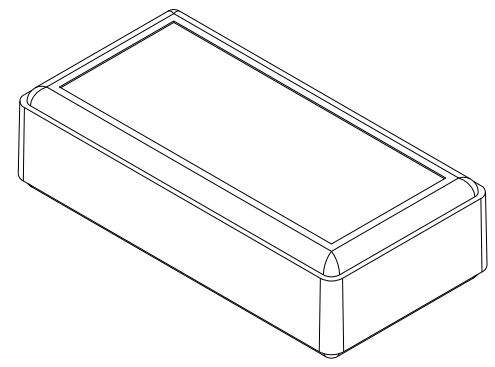
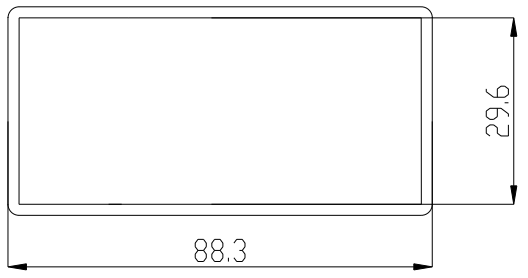

Referencia Electrónica Embajadores: CJPP95x

		Proprietary and confidential of Supertronic		
Plano		Formato DIN A4		
Dibujado	D.R.	Fecha 2007	Peso (gr) 20.0	Dimensiones 78x40x21
Revisado	J.R.	Fecha 2008	Escala 1/1.5	Material ABS
		Código	Dimensions are in millimeters Tolerance ±0.2mm	
Referencia cliente		Modelo PP95		