

CUERPO

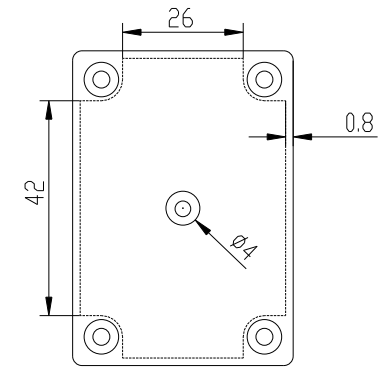
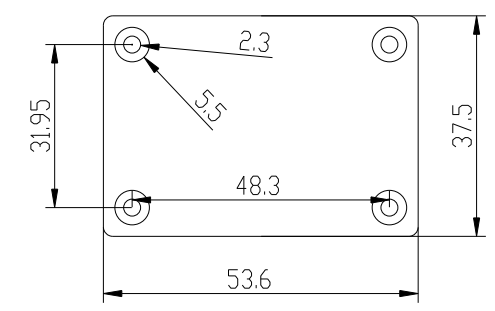
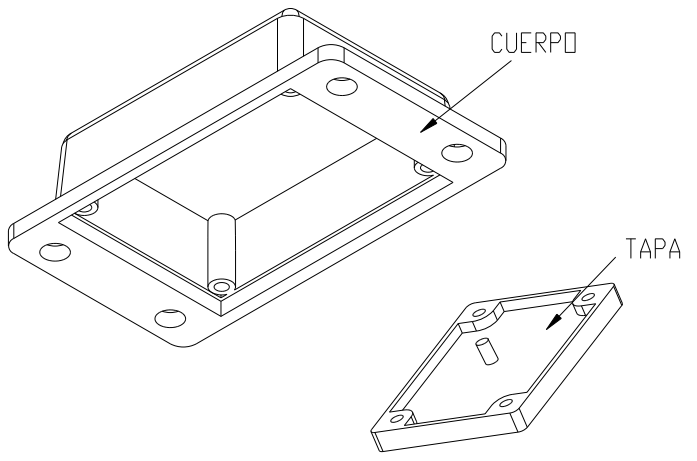
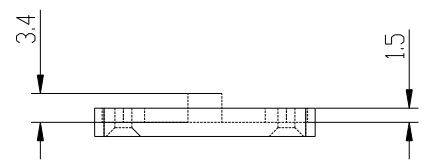
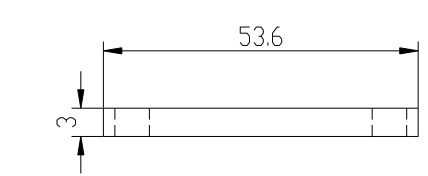
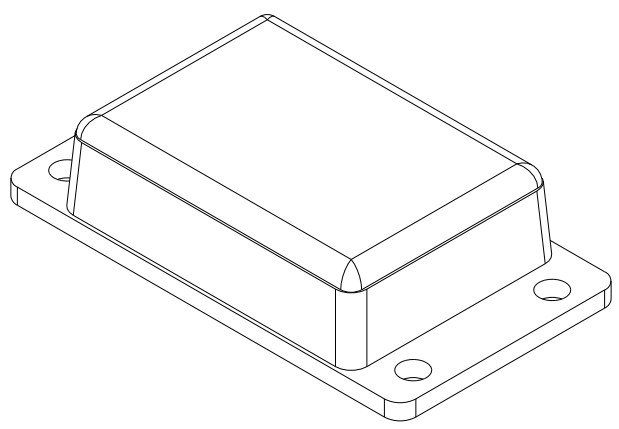
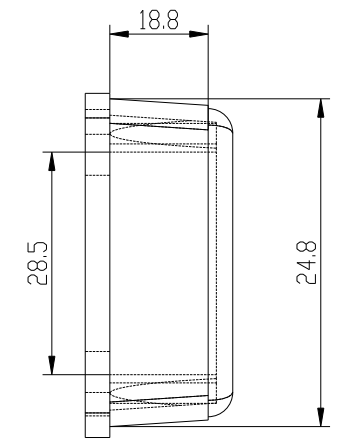
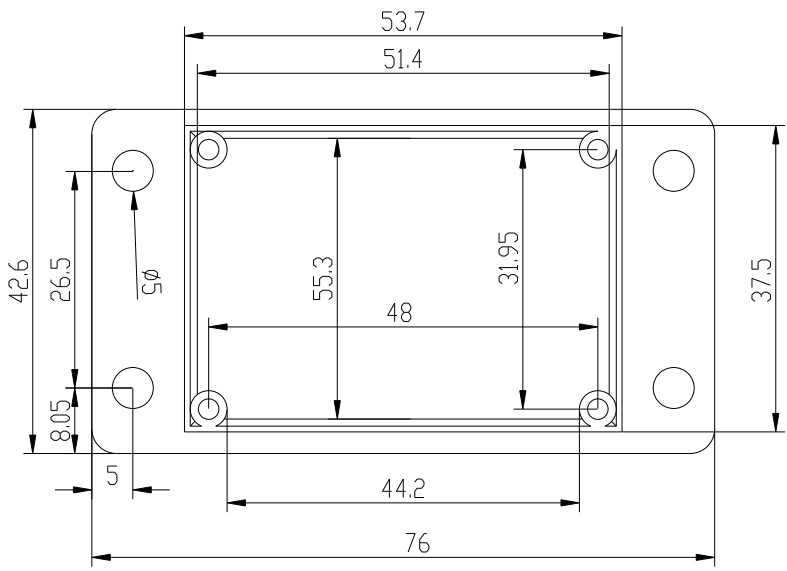

TAPA

Referencia Electrónica Embajadores: CJPP94xD

		Proprietary and confidential of Supertronic		
Plano		Formato DIN A4		
Dibujado	D.R.	Fecha 2007	Peso (gr) 23.7	Dimensiones 70x42x25
Revisado	J.R.	Fecha 2008	Escala 1/1	Material ABS
		Código	Dimensions are in millimeters Tolerance ±0.2mm	
Referencia cliente		Modelo PP94D		