

CUERPO

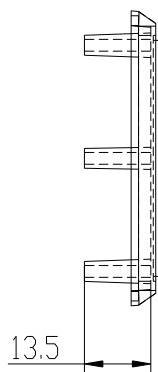

TAPA

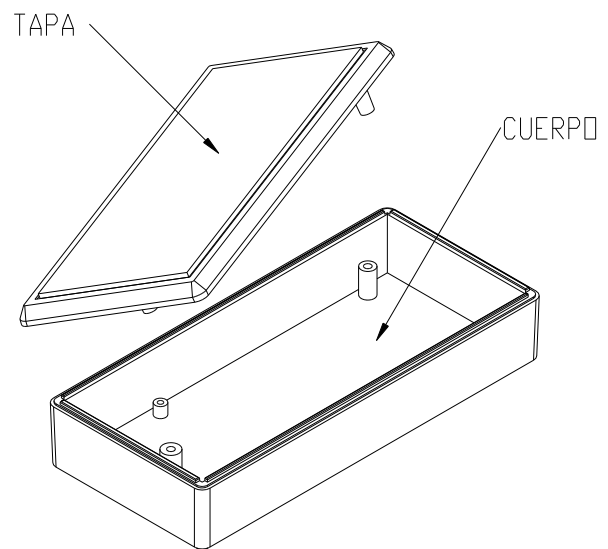
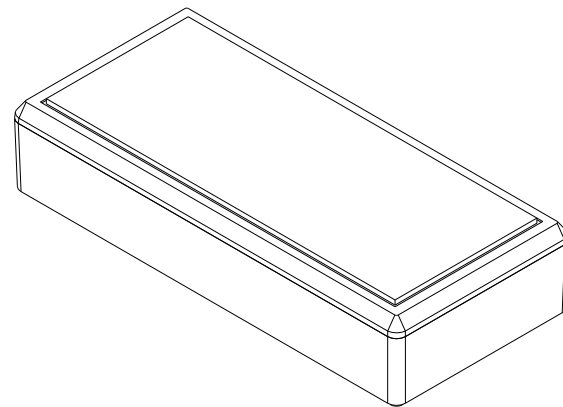

- 2 Tornillos 2.2x6.5 DIN 7982 2 Screws 2.2x6.5 DIN 7982
- 3 Tornillos 2.2x16 DIN 7981 3 Screw 2.2x16 DIN 7981

Referencia Electrónica Embajadores: CJPP8x

		Proprietary and confidential of Supertronic		
		Plano	Formato DIN A4	
Dibujado	D.R.	Fecha 2007	Peso (gr) 55.0	Dimensiones 131x60x29
Revisado	J.R.	Fecha 2008	Escala 1/1.5	Material ABS
		Código	Dimensions are in millimeters Tolerance ±0.2mm	
Referencia cliente		Modelo		PP8