

CUERPO

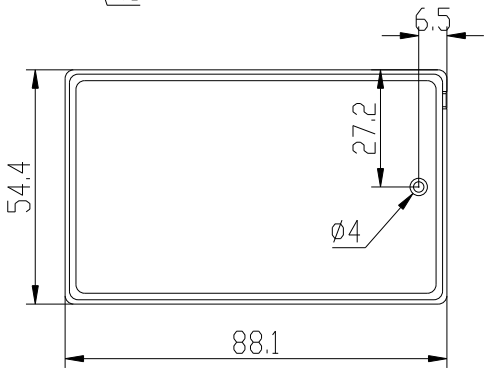

TAPA

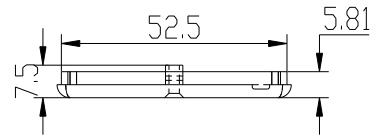
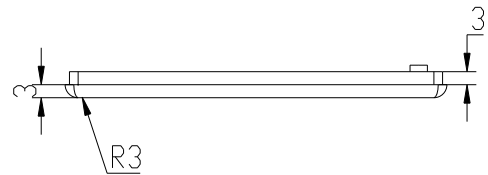
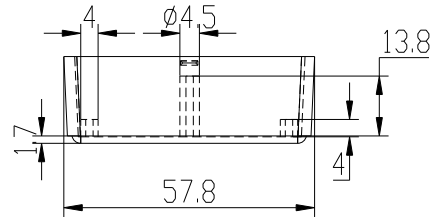
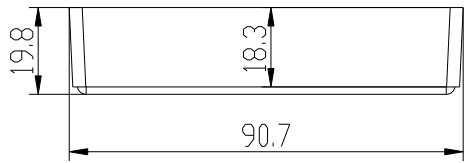
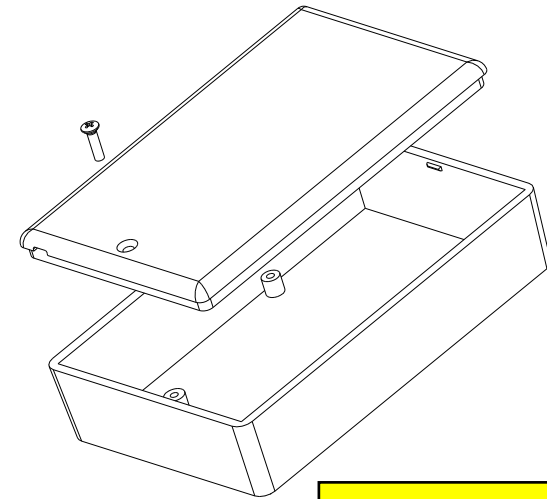
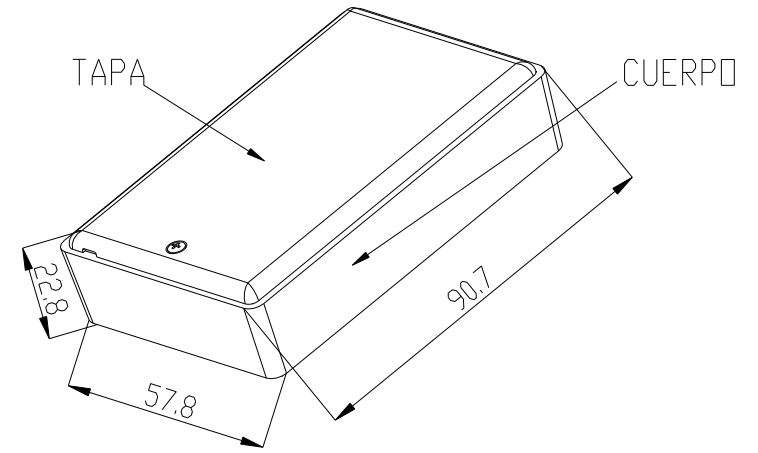

Referencia Electrónica Embajadores: CJPP6x

2 Tornillos 2.2x6.5 DIN 7982 2 Screws 2.2x6.5 DIN 7982
 1 Tornillos 2.2x13 DIN 7981 2 Screws 2.2x13 DIN 7981

		Proprietary and confidential of Supertronic		
		Plano	Formato DIN A4	
Dibujado	D.R.	Fecha 2007	Peso (gr) 30.5	Dimensiones 90x56x23
Revisado	J.R.	Fecha 2008	Escala 1/1.5	Material ABS
		Código	Dimensions are in millimeters Tolerance ±0.2mm	
Referencia cliente		Modelo PP6		