

TAPA

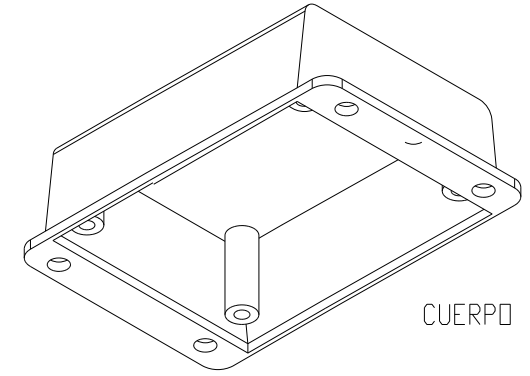

CUERPO

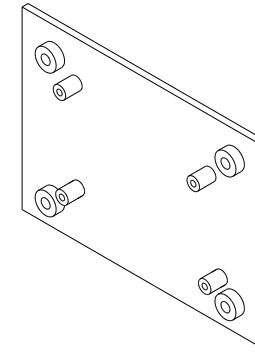
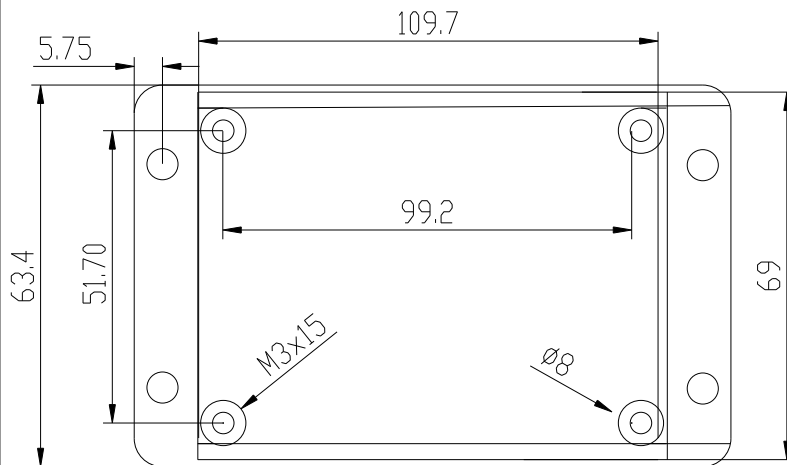
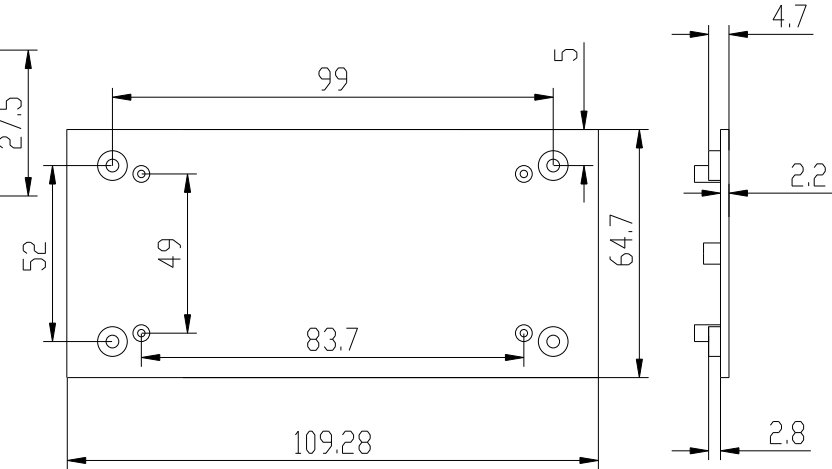
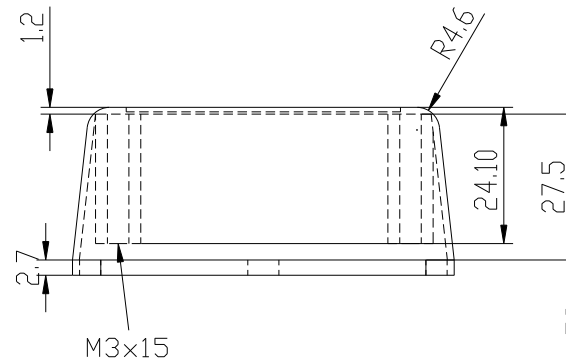
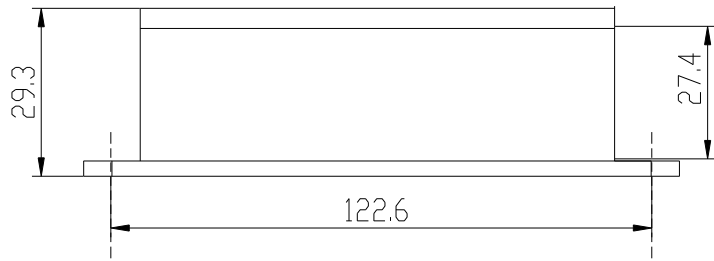

4 Tornillos M3x8 DIN 84-5.6
1 Tornillos 2.2x6.5 DIN 7981

4 Screws M3x8 DIN 84-5.6
1 Screws 2.2x6.5 DIN 7981

Referencia Electrónica Embajadores: CJPP45x

		Proprietary and confidential of Supertronic		
Plano		Formato DIN A4		
Dibujado	D.R.	Fecha 2007	Peso (gr) 57.3	Dimensiones 113x69x30
Revisado	J.R.	Fecha 2008	Escala 1/1.5	Material ABS
Código		Dimensions are in millimeters Tolerance ±0.2mm		
Referencia cliente		Modelo PP45		