

CUERPO

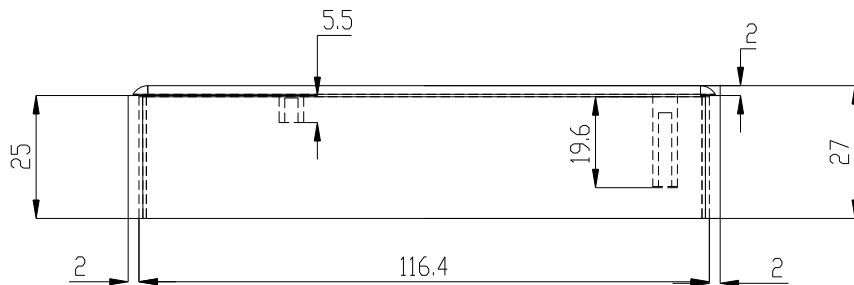

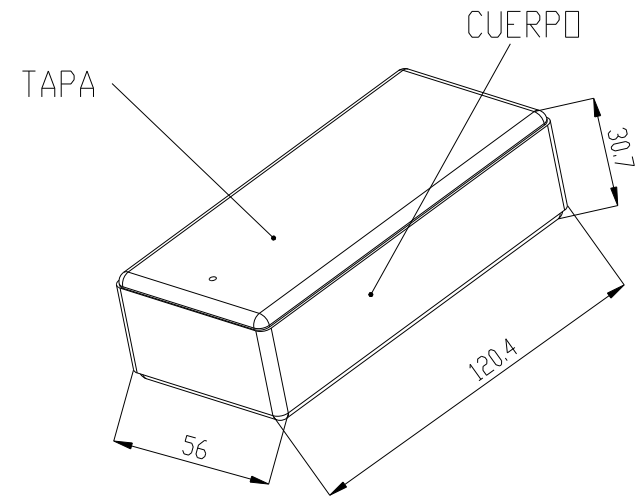

TAPA

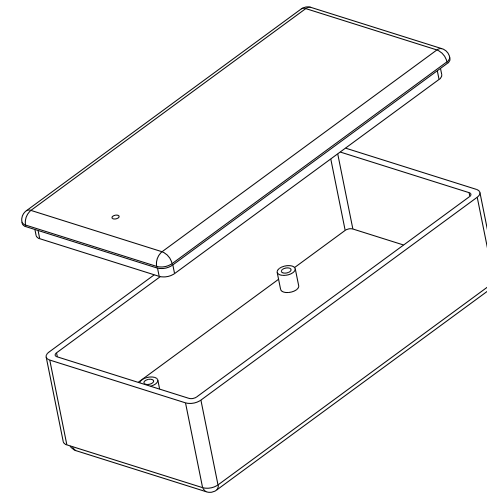

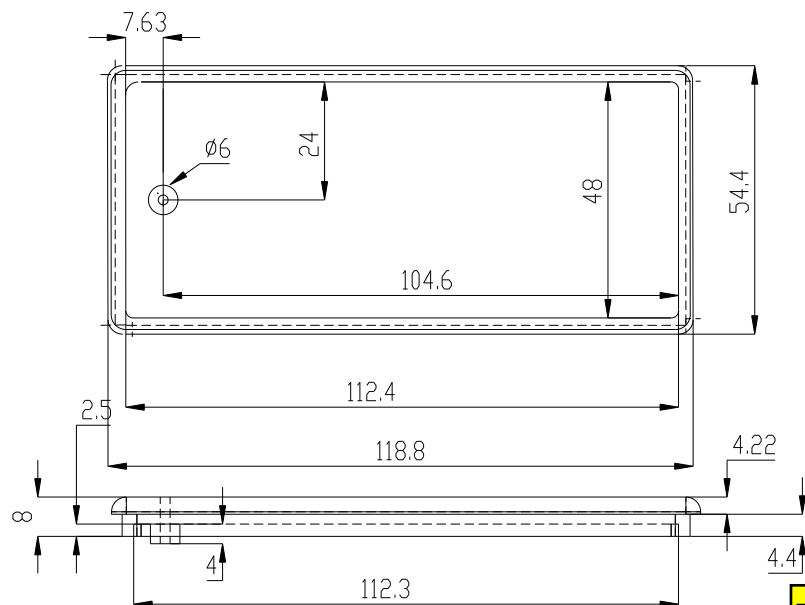
2 Tornillos M3x20 DIN 7505
2 Screws M3x20 DIN 7505



Referencia Electrónica Embajadores: CJPP4x

 SUPERTRONIC, S.A.		Proprietary and confidential of Supertronic		
Plano		Formato DIN A4		
Dibujado	D.R.	Fecha 2007	Peso (gr) 50	Dimensiones 121x55x31
Revisado	J.R.	Fecha 2008	Escala 1/1.5	Material ABS
		Código	Dimensions are in millimeters Tolerance ±0.2mm	
Referencia cliente		Modelo PP4		