

CUERPO

TAPA

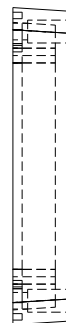

TAPA

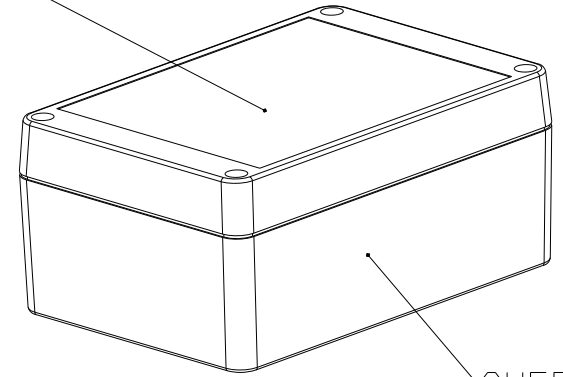

CUERPO

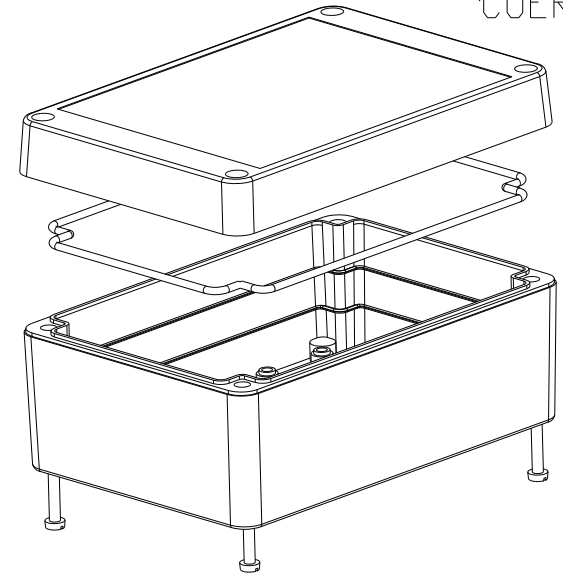

4 Tornillos M3x8 DIN 84-5.6
4 Tornillos 2.9x6.5 DIN 7981

4 Screws M3x8 DIN 84-5.6
4 Tornillo 2.9x6.5 DIN 7981



Proprietary and confidential of Supertronic
Plano Formato DIN A4

Dibujado	D.R.	Fecha 2007	Peso (gr) 145.5	Dimensiones 125x85x55
Revisado	J.R.	Fecha 2008	Escala 1/2	Material ABS

⊕ □ Código Dimensions are in millimeters Tolerance $\pm 0.2\text{mm}$

Referencia cliente Modelo PP76

Referencia Electrónica Embajadores: CJ41PP76x