

Spec No.	Date	Page	Ver.
A-TZ-029-00	2006/4/27	1/10	A-00

LED SPECIFICATION

PART NO. : EOZ-ZTFRCDO-EG

PART DESCRIPTION : 90° Green Super Flux LED

Product Description

Super Flux LEDs are made with super high brightness LED chips and low thermal resistance package. The package with low thermal resistance allows the lighting designers to drive these LEDs at higher current than the conventional through-hole LEDs. The advanced AlInGaP technology provides extremely high and stable light output over long period of time. With qualified advanced designed AlInGaP chips, EOI Super Flux LEDs can generate the same level of optical performance as it is by Lumileds' TS grade Piranha. Because Super Flux LED can emit more light, uniform and unique illuminated appearance, it allows the lighting designer to reduce the number of LEDs required through the efficient optical design and high-current electrical design.

Excellence opto. Inc. uses the brightest Red, Amber, Blue, and Green LED chips in this product family. The designers can select the most suitable color for many lighting applications, such as automobile signals, garden lightings, special lightings for building and electronic signs, and etc.



EOI			CUSTOMER APPROVED
ACTION	NAME	DATE	
PREPARED	<i>Calhy Huang</i>	<i>2006/4/27</i>	
CHECKED	<i>Vincent Huang</i>	<i>2006/4/27</i>	
APPROVED	<i>Ader Wu</i>	<i>2006/4/27</i>	

Spec No.	Date	Page	Ver.
A-TZ-029-00	2006/4/27	2/10	A-00

PART NO : EOZ-ZTFRC00-EG

Features

- ◆ High Luminance / High Light Output
- ◆ Low Thermal Resistance
- ◆ Low Profile
- ◆ Meet SAE/ECE/JIS Automotive Color Requirements
- ◆ Design for High Current Operation
- ◆ Pb free & RoHS Compliant Product

Applications

- ◆ Automotive Exterior Lighting
- ◆ Electronic Signs and Signals
- ◆ Specialty Lighting
- ◆ Decoration
- ◆ Channel Letter

Benefits

- ◆ Fewer LED Requirement
- ◆ Lower Application Cost

Outline Drawings

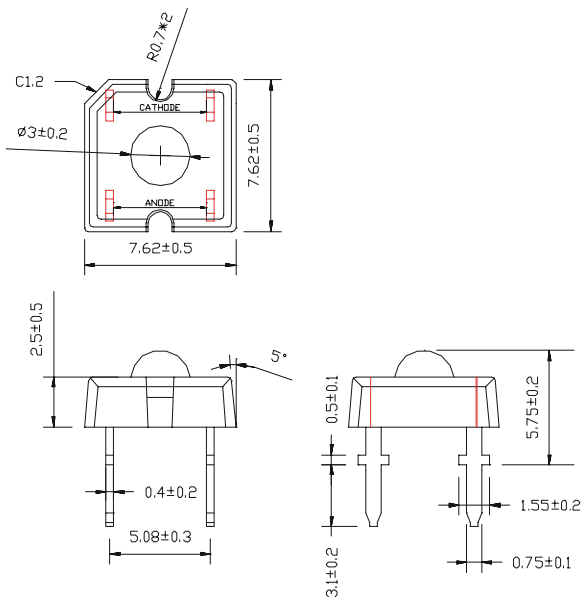

Notes:

1. All dimensions are in millimeter.
2. Tolerance is $\pm 0.20\text{mm}$ unless otherwise noted.
3. Protruded resin under bottom surface of epoxy is 1.5mm max.
4. Lead spacing is measured where the leads emerge from the package.

Beam Pattern

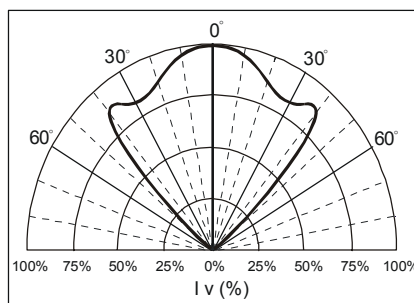

PART NO : EOZ-ZTFRC00-EG

Absolute Maximum Ratings at $T_A=25^\circ\text{C}$

Parameter	Symbol	MAX.	Unit
Average Forward Current ^{[a] [c]}	I_F	50	mA
Peak Forward Current ^[b]	I_{peak}	80	mA
Reverse Voltage	V_R	5	V
Power Dissipation	P_D	230	mW
Current Linearity vs. Ambient Temperature	TC_I	- 0.47	mA/°C
LED Junction Temperature	T_J	125	°C
Operating Temperature Range ^[c]	T_{OPR}	-40°C ~ +85°C	°C
Storage Temperature Range	T_{STO}	-40°C ~ +100°C	°C
Lead Soldering Condition [4mm(.157") away from epoxy]	T_{SOL}	260°C / 5 seconds	

Note: [a] Design of heat dissipation should be considered.

[b] Duty Ratio=1/10,Pulse Width=0.1ms.

[c]The allowable operating current at different operation temperature, please take reference from Fig 4 page 4.

Electrical and Optical Characteristics at $T_A=25^\circ\text{C}$

Parameter	Symbol	Min.	Typ.	Max.	Unit	Test Condition
Total Luminous Flux	Φ_v	2750	4500	---	mlm	$I_F=50\text{mA}$
Luminous Intensity / Total Flux	I_v / Φ_v	---	0.65	---	mcd / mlm	$I_F=50\text{mA}$
Viewing Angle	$2\theta_{1/2}$	---	90	---	Deg	$I_F=50\text{mA}$
Total Included Angle ^[1]	$\theta_{0.9}$	---	110	---	Deg	$I_F=50\text{mA}$
Dominant Wavelength	λ_d	519	525	531	nm	$I_F=50\text{mA}$
Spectral Half Width	$\Delta\lambda$	---	25	---	nm	$I_F=50\text{mA}$
Forward Voltage	V_F	3.2	4.0	4.6	V	$I_F=50\text{mA}$
Reverse Current	I_R	---	---	10	μA	$V_R=5\text{V}$
Thermal Resistance θ_{j-a}				300 (Typ.)	°C/W	$I_F=50\text{mA}$
Thermal Resistance θ_{j-pin}				130 (Typ.)	°C/W	$I_F=50\text{mA}$

Ranks Combination

Dominant Wavelength λ_D (nm) @ $I_F=50\text{mA}$			Total Flux Φ_v (mlm) @ $I_F=50\text{mA}$			Forward Voltage V_F (v) @ $I_F=50\text{mA}$					
Code	min	max	Code	min	max	Code	min	max	Code	min	max
F5	519	523	2E	2780	3850	G	3.2	3.4	D	4.0	4.2
F6	523	527	2F	3850	5400	A	3.4	3.6	E	4.2	4.4
F7	527	531	2G	5400	7600	B	3.6	3.8	F	4.4	4.6
-	-	-	-	-	-	C	3.8	4.0	-	-	-

Note:

- Viewing angle 0.9V is the included angle at which 90% of total luminous flux is captured.
- All of rank combinations which include luminous intensity, dominant wavelength, and forward voltage will be included in every shipment.
- Measurement Uncertainty of the Total flux: $\pm 15\%$
- Measurement Uncertainty of the Dominant Wavelength: $\pm 1\text{nm}$
- Measurement Uncertainty of the Voltage: $\pm 0.05\text{V}$

Spec No.	Date	Page	Ver.
A-TZ-029-00	2006/4/27	4/10	A-00

PART NO : EOZ-ZTFRC0-EG

Typical Electrical / Optical Characteristics Curves

(25°C Ambient Temperature Unless Otherwise Noted)

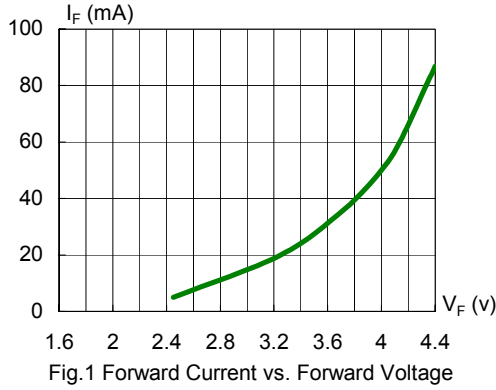

Fig.1 Forward Current vs. Forward Voltage

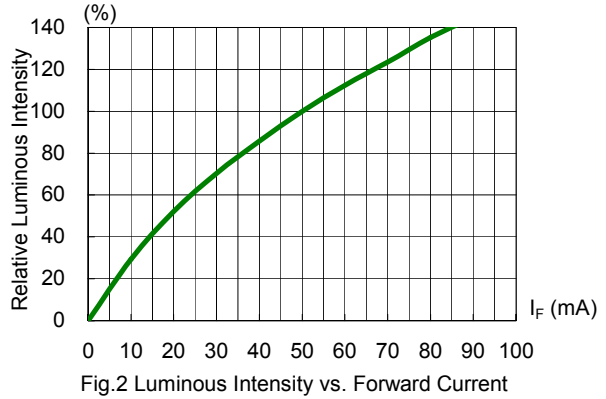

Fig.2 Luminous Intensity vs. Forward Current

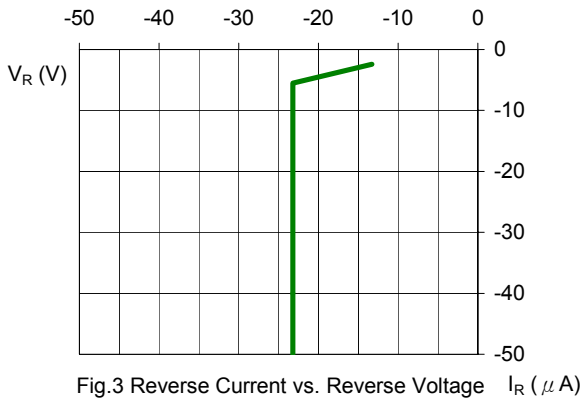

Fig.3 Reverse Current vs. Reverse Voltage

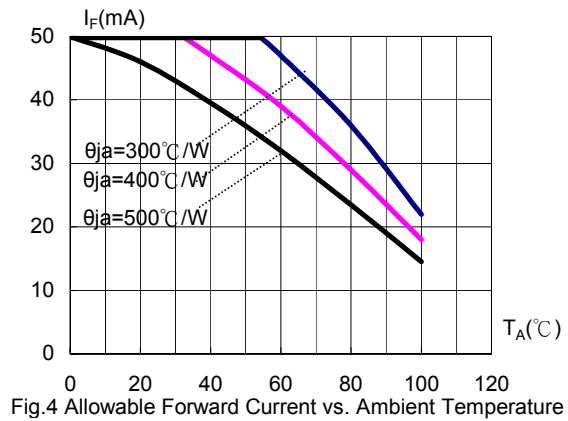

Fig.4 Allowable Forward Current vs. Ambient Temperature

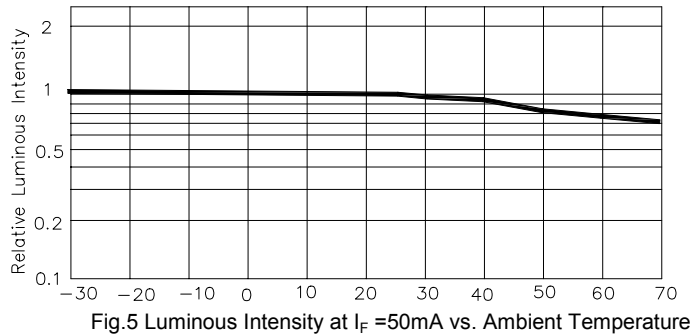

Fig.5 Luminous Intensity at $I_F = 50mA$ vs. Ambient Temperature

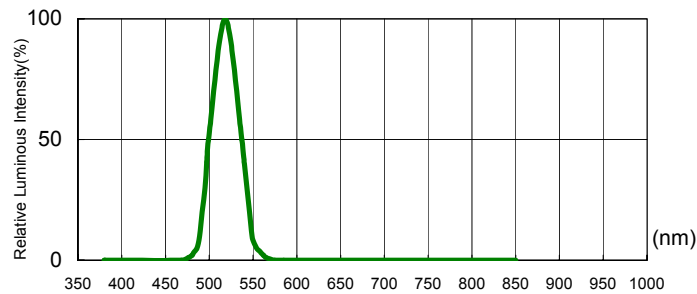

Fig.6. Relative Luminous Intensity vs. Wavelength

Note: The data shown above are typical curves. Every LED component may have some variations of characteristics.

PART NO : EOZ-ZTFRCDO-EG

Spec No.	Date	Page	Ver.
A-TZ-029-00	2006/4/27	5/10	A-00

Reliability Test

EOI'S LED lamps are checked by reliability test based on MIL standards.

1. Test Conditions, Acceptable Criteria & Results:

Classification	Test Item	Standard Test Method	Test Conditions	Duration	Unit	Acc / Rej Criteria	Result
Life Test	Operation Life Test (OLT)	MIL-STD-750D Method 1026.3	$T_A=25^{\circ}\text{C}$, $I_F=70\text{mA}$ *	1000 Hrs	100	0 / 1	Pass
Environment Test	High Temperature Storage (HTS)	MIL-STD-750D Method 1032.1	$T_A=100^{\circ}\text{C}$	1000 Hrs	100	0 / 1	Pass
	Low Temperature Storage (LTS)	MIL-STD-750D Method 1032.1	$T_A=-40^{\circ}\text{C}$	1000 Hrs	100	0 / 1	Pass
	Temp. & Humidity with Bias (THB)	MIL-STD-750D Method 103B	$T_A=85^{\circ}\text{C}$, Rh=85% $I_F=45\text{mA}$ **	500 Hrs	100	0 / 1	Pass
	Thermal Shock Test (TST)	MIL-STD-750D Method 1056.1	$0^{\circ}\text{C} \sim 100^{\circ}\text{C}$ 2min 2min	100 cycles	100	0 / 1	Pass
	Temperature Cycling Test (TCT)	MIL-STD-750D Method 1051.5	$-40^{\circ}\text{C} \sim 25^{\circ}\text{C} \sim 100^{\circ}\text{C} \sim 25^{\circ}\text{C}$ 30min 5min 30min 5min	100 cycles	100	0 / 1	Pass
Mechanical Test	Solderability	MIL-STD-750D Method 2026.4	$235\pm 5^{\circ}\text{C}$, 5 sec	1 time	20	0 / 1	Pass
	Resistance to Soldering Heat	MIL-STD-750D Method 2031.1	$260\pm 5^{\circ}\text{C}$, 10 sec	1 time	20	0 / 1	Pass
	Lead Integrity	MIL-STD-750D Method 2036.3	Load 2.5N (0.25kgf) $0^{\circ} \sim 90^{\circ} \sim 0^{\circ}$, bend	3 times	20	0 / 1	Pass

Remark : (*) $I_F=70\text{mA}$ for AllInGaP chip ; $I_F=50\text{mA}$ for InGaN chip

(**) $I_F=45\text{mA}$ for AllInGaP chip ; $I_F=30\text{mA}$ for InGaN chip

2. Failure Criteria ($T_A=25^{\circ}\text{C}$):

Test Item	Symbol	Test Conditions	Criteria for Judgment	
			Min.	Max.
Luminous Intensity	I_V	$I_F=20\text{mA}$	$\text{LSL}\times 0.5$ **	
Voltage (Forward)	V_F	$I_F=20\text{mA}$		$\text{USL}\times 1.1$ *

(*) USL : Upper Standard Level , (**) LSL : Lower Standard Level

PART NO : EOZ-ZTFRCDD0-EG

Spec No.	Date	Page	Ver.
A-TZ-029-00	2006/4/27	6/10	A-00

Shipment Package

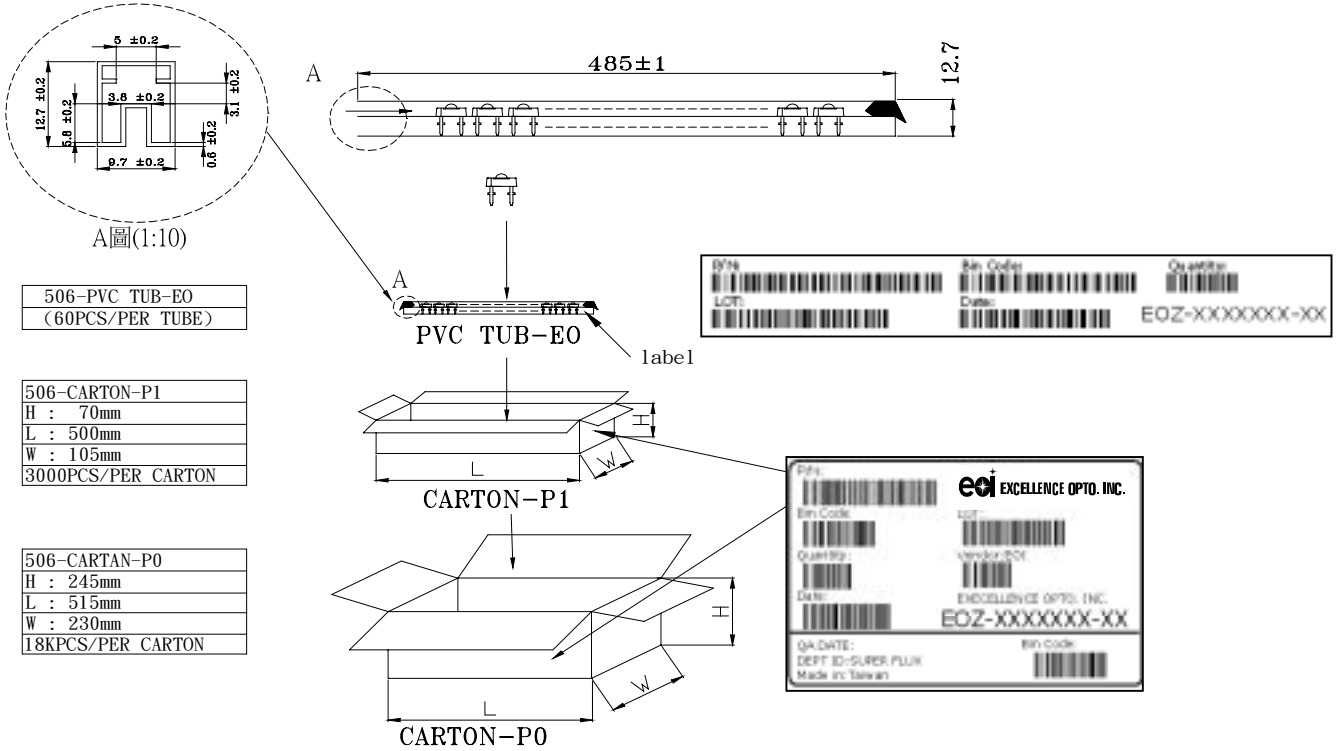

Precaution of Application

1. Circuit layout

Due to the forward voltage of LED will vary with temperature and its driving current, the current-limited protective circuit should be considered in the LED circuit design.

When LEDs are arrayed as parallel circuit, different inherent resistance of LED will cause unbalance current. The unbalanced driving current which exists in every parallel circuit may make LED to be driven at different power. Therefore, the LED driven at higher power may be damaged by over driving current, and the LED driven at lower power may be dimmer than the others.

To solve this situation, a suitable resistor is recommended to put in series with each LED circuit. The resistor will limit and balance the driving current which flow through every parallel circuits.

PART NO : EOZ-ZTFRCDD0-EG

Spec No.	Date	Page	Ver.
A-TZ-029-00	2006/4/27	7/10	A-00

2. Electric Static Discharge (ESD) Protection

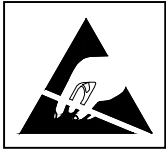

ESD protection for GaP and AlGaAs chips are still necessary even though they are safety in low static-electric discharge. Material in AlInGaP, GaN, or/and InGaN chips are STATIC SENSITIVE device. ESD protection shall be considered and taken in the initial design stage.

If manual work/process is needed, please ensure the device is well protected from ESD within all the process.

3. Lead Forming

The leads should not be bent at the point of 3mm or below 3mm from the base of the epoxy bulb while forming the leads.

Do not apply any bending stress to the base of the lead, and don't cause any stress after mounting the LED lamp on PCB. The stress to the base may damage the LED's characteristics, or cause deterioration of the epoxy resin. This will hurt and degrade the LEDs.

4. Storage

It's recommended to store the products in the following conditions:

Humidity (Hum.) : 60%RH Max.

Temperature (T_A) : 5°C ~ 30°C (41°F ~ 86°F)

Shelf life in sealed bag: 12 month at $T_A < 25^\circ\text{C}$ ~ 30°C and Hum.<30%RH.

After the package is opened, the products should be used within 72hrs.

Or they should be kept at Hum. $\leq 20\%$ RH in zip-locked sealed bags.

Although the leads of LED lamp is plated with pure tin to protect leads from corrosion, devices should be subjected to wave soldering, or equivalent process as soon as possible, after the bag is opened.

Please avoid rapid transitions in ambient temperature, especially in high humidity environment where condensation can occur.

Spec No.	Date	Page	Ver.
A-TZ-029-00	2006/4/27	8/10	A-00

PART NO : EOZ-ZTFRCDO-EG

5. Soldering

Soldering heat may damage the LED. Careful attention should be paid during soldering process.

Solder the LEDs no close than 3mm form the base of the epoxy bulb.

Recommended SnPb reflow soldering profile:

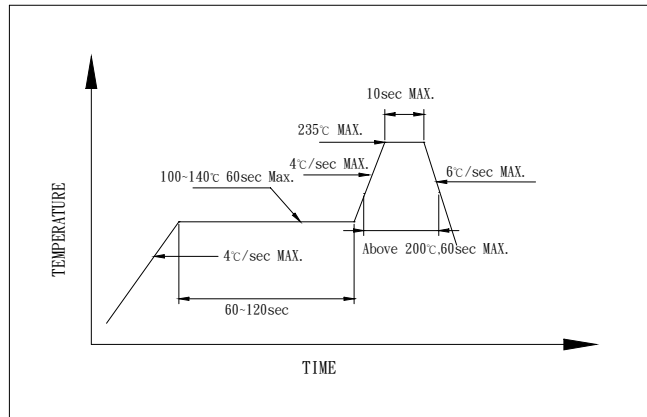

Recommended Pb free reflow soldering profile:

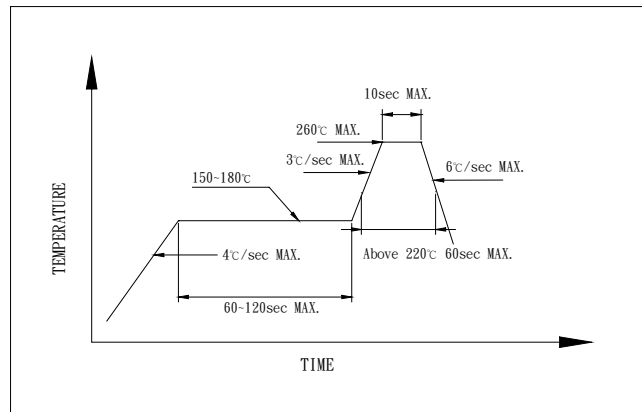

Never take next process until the component is cooled down to room temperature after soldering. It's banned to load any stress on the resin during soldering. If it's necessary to clamp the LED bulbs to help soldering, it is important to minimize the mechanical stress on the LEDs.

The manual soldering process is not recommended for quality consideration. When it is absolutely necessary, the LEDs may be mounted in this fashion but the user will assume responsibility for any problems.

PART NO : EOZ-ZTFRC00-EG

Spec No.	Date	Page	Ver.
A-TZ-029-00	2006/4/27	9/10	A-00

6. Cleaning

An alcohol-based solvent such as isopropyl alcohol (IPA) is recommended to clean the LED bulbs, after soldering process. Before cleaning, a pre-test should be done to confirm whether any damage to the LEDs will occur.

7. Others

Heat generation:

- LED lamp is very sensitive to heat. Thermal design of the end product will decide the performance of LED lamps. It's necessary to avoid intense heat generation and operate within the maximum ratings given in this specification.
- PCB Layout of LEDs can be considered to enhance the heat dissipation. Please enlarge the copper area at the cup (cathode) side of LEDs. The larger copper trace of PCB will help thermal dissipation, when LED is turned on.

PART NO : EOZ-ZTFRC00-EG

Spec No.	Date	Page	Ver.
A-TZ-029-00	2006/4/27	10/10	A-00

Terms and Conditions

1. EOI warrants all sold LEDs which conform to the specifications approved by the customers.
2. Any LED supplied by EOI is found not conform to the specifications that both parties agreed upon, customer should claim within 90days of receipt. EOI will repair or replace the LEDs at EOI's option.
3. EOI will not hold any responsibility for the failed LEDs, which are caused by mishandling or misusing the LEDs exceeding the operating conditions that EOI suggested.
4. EOI's LED products are designed and manufactured for general electronic equipment (such as household appliances, communication equipment, office equipment, electronic instrumentation and so on). If customer's application requires exceptional quality or reliability, which might concern human safety, it is recommended to consult with EOI in advance.
5. All the information published is considered to be reliable. However, EOI does not assume any liability arising out of the application or use of any product described herein. EOI's liability for defective LED lamps shall only be limited to replacement, in no event shall EOI be liable for consequential damages or loss.
6. EOI and customer shall both confirm the specifications herein, and all quality related matters will base on the specifications both parties agreed upon.
7. Any modification of the design or manufacturing process taken place, which will affect the characteristics, performance or reliability of LED, customer's approval will be required.
8. This specification approval sheet is an agreement of shipment specification. Please sign it back and keep the copies in two parties. If customers don't sign it back, it is regarded as completely agree with the terms and conditions and also approve of this approval sheet.

Company Information

Headquarters

5F, No. 1, Creation Road II, Hsinchu Science Park,
HsinChu, Taiwan 300, R.O.C.

TEL: 886-3-5679000

FAX: 886-3-5679999

<http://www.eoi.com.tw>

E-mail: Service@eoi.com.tw



U.S. Office

1400 W. Lambert Road, Suite B, Brea CA92821

TEL: 1-562-694-1246, 1-562-694-1427

FAX: 1-562-691-3087

<http://www.eoi-us.com>

E-mail: Sales@eoius.com