

Spec No.	Date	Page	Ver.
A-Z-045-00	2008/9/10	1/11	A-00

LED SPECIFICATION

PART NO. : EOZ-ZAWNPD0-EG

PART DESCRIPTION : 60° White Super Flux LED

Product Description

Super Flux LEDs are made with super high brightness LED chips and low thermal resistance package. The package with low thermal resistance allows the lighting designers to drive these LEDs at higher current than the conventional through-hole LEDs. The advanced AlInGaP technology provides extremely high and stable light output over long period of time. With qualified advanced designed AlInGaP chips, EOI Super Flux LEDs can generate the same level of optical performance as it is by Lumileds' TS grade Piranha. Because Super Flux LED can emit more light, uniform and unique illuminated appearance, it allows the lighting designer to reduce the number of LEDs required through the efficient optical design and high-current electrical design.

Excellence opto. Inc. uses the brightest Red, Amber, Blue, and Green LED chips in this product family. The designers can select the most suitable color for many lighting applications, such as automobile signals, garden lightings, special lightings for building and electronic signs, and etc.



EOI			CUSTOMER APPROVED
ACTION	NAME	DATE	
PREPARED	<i>Calhy Huang</i>	<i>2008/9/10</i>	
CHECKED	<i>Vincent Huang</i>	<i>2008/9/10</i>	
APPROVED	<i>Ader Wu</i>	<i>2008/9/10</i>	

Spec No.	Date	Page	Ver.
A-Z-045-00	2008/9/10	2/11	A-00

PART NO : EOZ-ZAWNPD0-EG

Features

- ◆ High Luminance
- ◆ Low Thermal Resistance
- ◆ Low Profile
- ◆ Design for High Current Operation
- ◆ Pb free & RoHS Compliant Product

Applications

- ◆ Automotive Exterior Lighting
- ◆ Electronic Signs and Signals
- ◆ Specialty Lighting
- ◆ Decoration

Benefits

- ◆ Fewer LED Requirement
- ◆ Lower Application Cost

Outline Drawings

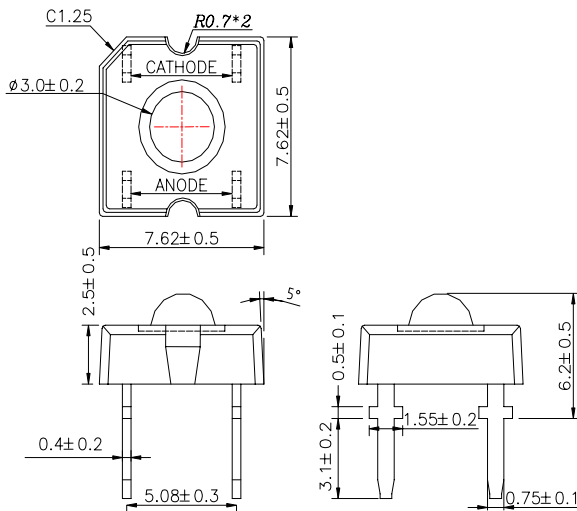

Notes:

1. All dimensions are in millimeter.
2. Tolerance is ± 0.20 mm unless otherwise noted.
3. Protruded resin under bottom surface of epoxy is 1.5mm max.
4. Lead spacing is measured where the leads emerge from the package.

Beam Pattern

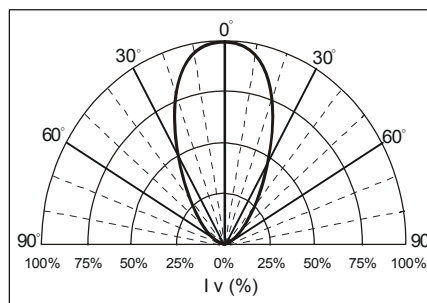

PART NO : EOZ-ZAWNPD0-EG

Absolute Maximum Ratings at T_A=25°C

Parameter	Symbol	MAX.	Unit
Average Forward Current ^{[a] [c]}	I _F	50	mA
Peak Forward Current ^[b]	I _{peak}	80	mA
Reverse Voltage	V _R	5	V
Power Dissipation	P _D	230	mW
Current Linearity vs. Ambient Temperature	TC _I	- 0.48	mA/°C
LED Junction Temperature	T _J	125	°C
Operating Temperature Range ^[c]	T _{OPR}	-40°C ~ +100°C	°C
Storage Temperature Range	T _{STO}	-40°C ~ +100°C	°C
Lead Soldering Condition [4mm(.157") away from epoxy]	T _{SOL}	260°C / 5 seconds	

Note: [a] Design of heat dissipation should be considered.

[b] Duty Ratio=1/10,Pulse Width=0.1ms.

[c]The allowable operating current at different operation temperature, please take reference from Fig 4 page 4.

Electrical and Optical Characteristics at T_A =25°C

Parameter	Symbol	Min.	Typ.	Max.	Unit	Test Condition
Total Luminous Flux	Φ _v	3850	6000	---	mlm	I _F =50mA
Luminous Intensity / Total Flux	I _v / Φ _v	---	0.84	---	mcd / mlm	I _F =50mA
Viewing Angle	2θ _{1/2}	---	60	---	Deg	I _F =50mA
Total Included Angle	θ _{0.9}	---	100	---	Deg	I _F =50mA
Chromaticity Coordinate	x	---	0.31	---	---	I _F =50mA
	y	---	0.32	---	---	
Forward Voltage	V _F	3.0	4.0	4.6	V	I _F =50mA
Reverse Current	I _R	---	---	10	μA	V _R =5V
Thermal Resistance θ _{j-a}		400 (Typ.)			°C/W	I _F =50mA
Thermal Resistance θ _{j-pin}		180 (Typ.)			°C/W	I _F =50mA

Ranks Combination

Total Flux Φ _v (mlm) @I _F =50mA			Forward Voltage V _F (v) @I _F =50mA					
min	max	Code	min	max	Code	min	max	Code
3850	5400	2F	3.0	3.2	K	3.8	4.0	C
5400	7600	2G	3.2	3.4	G	4.0	4.2	D
7600	10000	2H*	3.4	3.6	A	4.2	4.4	E
-	-	-	3.6	3.8	B	4.4	4.6	F

Note:

- Viewing angle 0.9V is the included angle at which 90% of total luminous flux is captured.
- All of rank combinations which include luminous intensity, dominant wavelength, and forward voltage will be included in every shipment.
- Measurement Uncertainty of the Total flux: ±15%
- Measurement Uncertainty of the Chromatic Coordinates: ±0.01
- Measurement Uncertainty of the Voltage: ±0.05V
- [*] Bin with less distribution

Spec No.	Date	Page	Ver.
A-Z-045-00	2008/9/10	4/11	A-00

PART NO : EOZ-ZAWNPD0-EG

Chromaticity Coordinates Specifications for Bin Grading

Typical CCT (K)	Bin Code	CIE BIN CODE
18000	A1	(0.250,0.165)(0.260,0.180)(0.260,0.223)(0.250,0.208)
	A2	(0.250,0.208)(0.260,0.223)(0.260,0.265)(0.250,0.250)
13000	B1	(0.260,0.180)(0.270,0.195)(0.270,0.238)(0.260,0.223)
	B2	(0.260,0.223)(0.270,0.238)(0.270,0.280)(0.260,0.265)
10500	C1	(0.270,0.195)(0.280,0.210)(0.280,0.253)(0.270,0.238)
	C2	(0.270,0.238)(0.280,0.253)(0.280,0.295)(0.270,0.280)
8900	D1	(0.280,0.210)(0.290,0.225)(0.290,0.268)(0.280,0.253)
	D2	(0.280,0.253)(0.290,0.268)(0.290,0.310)(0.280,0.295)
7700	E1	(0.290,0.225)(0.300,0.240)(0.300,0.283)(0.290,0.268)
	E2	(0.290,0.268)(0.300,0.283)(0.300,0.325)(0.290,0.310)
6850	F1	(0.300,0.240)(0.310,0.255)(0.310,0.298)(0.300,0.283)
	F2	(0.300,0.283)(0.310,0.298)(0.310,0.340)(0.300,0.325)
6250	G1	(0.310,0.255)(0.320,0.270)(0.320,0.313)(0.310,0.298)
	G2	(0.310,0.298)(0.320,0.313)(0.320,0.355)(0.310,0.340)
5750	H1	(0.320,0.270)(0.330,0.285)(0.330,0.328)(0.320,0.313)
	H2	(0.320,0.313)(0.330,0.328)(0.330,0.370)(0.320,0.355)
5350	J1	(0.330,0.285)(0.340,0.300)(0.340,0.343)(0.330,0.328)
	J2	(0.330,0.328)(0.340,0.343)(0.340,0.385)(0.330,0.370)
4950	K1	(0.340,0.300)(0.350,0.315)(0.350,0.358)(0.340,0.343)
	K2	(0.340,0.343)(0.350,0.358)(0.350,0.400)(0.340,0.385)

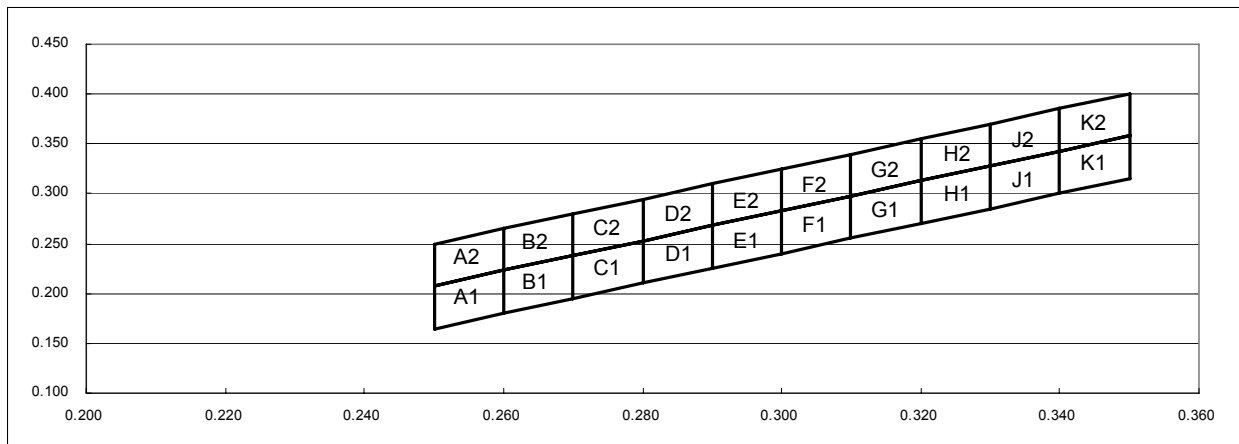

Spec No.	Date	Page	Ver.
A-Z-045-00	2008/9/10	5/11	A-00

PART NO : EOZ-ZAWNPD0-EG

Typical Electrical / Optical Characteristics Curves

(25°C Ambient Temperature Unless Otherwise Noted)

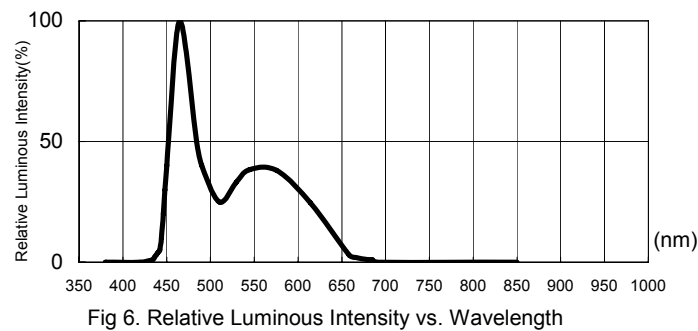
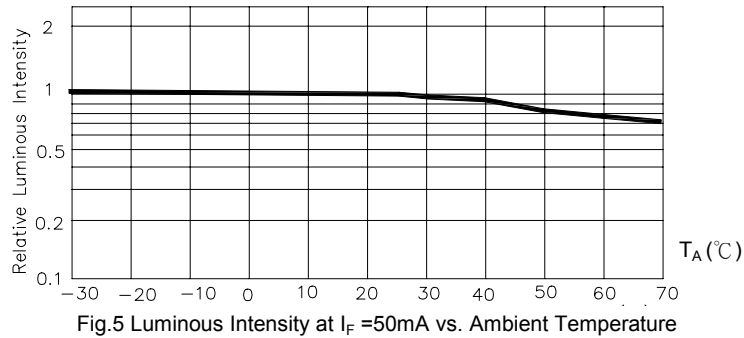
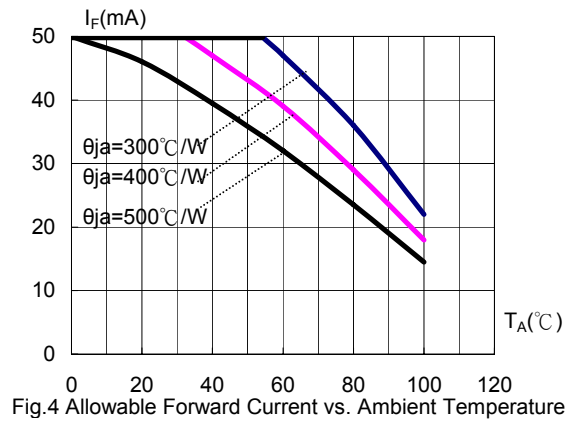
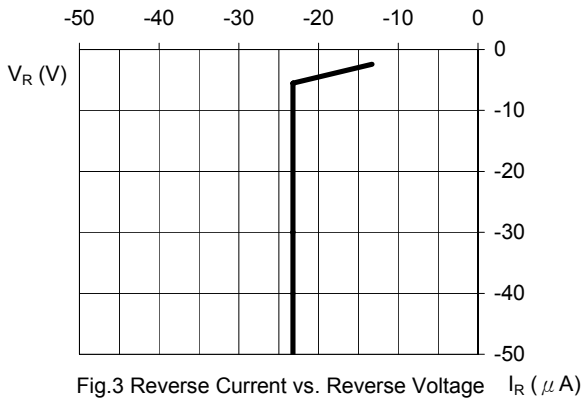
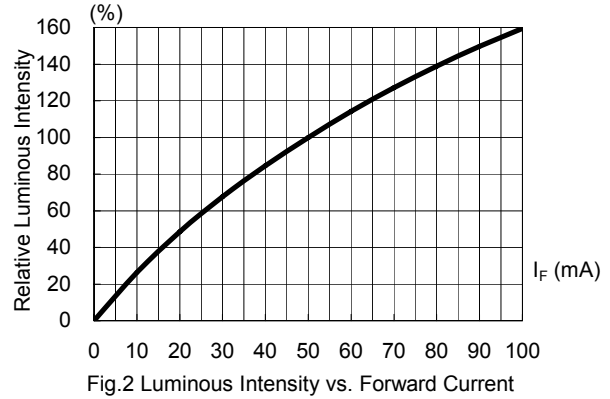
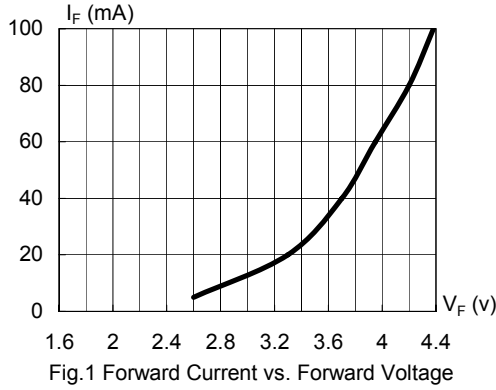

Note: The data shown above are typical curves. Every LED component may have some variations of characteristics.

PART NO : EOZ-ZAWNPD0-EG

Reliability Test

EOI's LED lamps are checked by reliability test based on MIL standards.

1. Test Conditions, Acceptable Criteria & Results:

Classification	Test Item	Standard Test Method	Test Conditions	Duration	Unit	Acc / Rej Criteria	Result
Life Test	Operation Life Test (OLT)	MIL-STD-750D Method 1026.3	$T_A=25^{\circ}\text{C}$, $I_F=70\text{mA}$ *	1000 Hrs	100	0 / 1	Pass
Environment Test	High Temperature Storage (HTS)	MIL-STD-750D Method 1032.1	$T_A=100^{\circ}\text{C}$	1000 Hrs	100	0 / 1	Pass
	Low Temperature Storage (LTS)	MIL-STD-750D Method 1032.1	$T_A=-40^{\circ}\text{C}$	1000 Hrs	100	0 / 1	Pass
	Temp. & Humidity with Bias (THB)	MIL-STD-750D Method 103B	$T_A=85^{\circ}\text{C}$, Rh=85% $I_F=45\text{mA}$ **	500 Hrs	100	0 / 1	Pass
	Thermal Shock Test (TST)	MIL-STD-750D Method 1056.1	$0^{\circ}\text{C} \sim 100^{\circ}\text{C}$ 2min 2min	100 cycles	100	0 / 1	Pass
	Temperature Cycling Test (TCT)	MIL-STD-750D Method 1051.5	$-40^{\circ}\text{C} \sim 25^{\circ}\text{C} \sim 100^{\circ}\text{C} \sim 25^{\circ}\text{C}$ 30min 5min 30min 5min	100 cycles	100	0 / 1	Pass
Mechanical Test	Solderability	MIL-STD-750D Method 2026.4	$235\pm 5^{\circ}\text{C}$, 5 sec	1 time	20	0 / 1	Pass
	Resistance to Soldering Heat	MIL-STD-750D Method 2031.1	$260\pm 5^{\circ}\text{C}$, 5 sec	1 time	20	0 / 1	Pass
	Lead Integrity	MIL-STD-750D Method 2036.3	Load 2.5N (0.25kgf) $0^{\circ} \sim 90^{\circ} \sim 0^{\circ}$, bend	3 times	20	0 / 1	Pass

Remark : (*) $I_F=70\text{mA}$ for AllInGaP chip ; $I_F=50\text{mA}$ for InGaN chip

(**) $I_F=45\text{mA}$ for AllInGaP chip ; $I_F=30\text{mA}$ for InGaN chip

2. Failure Criteria ($T_A=25^{\circ}\text{C}$):

Test Item	Symbol	Test Conditions	Criteria for Judgment	
			Min.	Max.
Luminous Intensity	I_V	$I_F=20\text{mA}$	LSL $\times 0.5$ **	
Forward Voltage	V_F	$I_F=20\text{mA}$		USL $\times 1.1$ *

(*) USL : Upper Standard Level , (**) LSL : Lower Standard Level

Spec No.	Date	Page	Ver.
A-Z-045-00	2008/9/10	7/11	A-00

PART NO : EOZ-ZAWNPD0-EG

Shipment Package

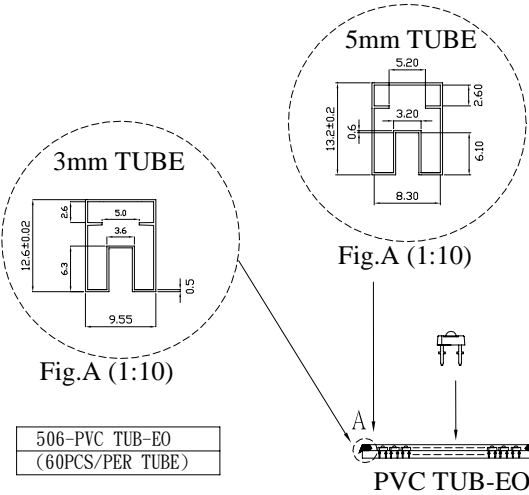

506-PVC TUB-EO (60PCS/PER TUBE)

P/N:EOZ-XXXXXXXX-XX	Bin Code:XXXXXX	Quantity:60
LOT:MO006XXXXXX	Date:20080820	EOZ-XXXXXXX-XX

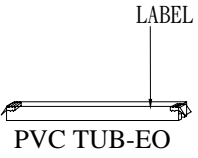

506-CARTON-P1 H : 72mm L : 492mm W : 100mm 3000PCS/PER CARTON

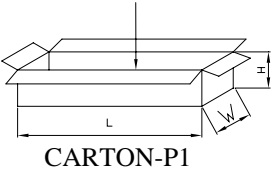

P/N:EOX-XXXXXXXX-XX	EOI EXCELLENCE OPTO. INC.
LOT:XXXXXXXXXX	EOX-XXXXXXX-XX
Bin Code:XXXXXX	PROGRAM:
QTY(pcs):XXXX	CARTON-ID:
QA Date:	
DEPT ID:S/F	



EOI EXCELLENCE OPTO. INC.		
Customer		
P.O.No		
Part No.	Bin Code	Qty(PCS)
Total		

506-CARTAN-P0 H : 245mm L : 505mm W : 225mm 18KPCS/PER CARTON

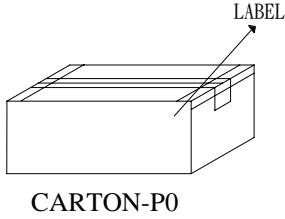
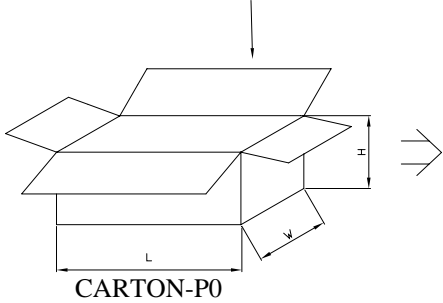

PART NO : EOZ-ZAWNPD0-EG

Spec No.	Date	Page	Ver.
A-Z-045-00	2008/9/10	8/11	A-00

Precaution of Application

1. Circuit layout

Due to the forward voltage of LED will vary with temperature and its driving current, the current-limited protective circuit should be considered in the LED circuit design.

When LEDs are arrayed as parallel circuit, different inherent resistance of LED will cause unbalance current. The unbalanced driving current which exists in every parallel circuit may make LED to be driven at different power. Therefore, the LED driven at higher power may be damaged by over driving current, and the LED driven at lower power may be dimmer than the others.

To solve this situation, a suitable resistor is recommended to put in series with each LED circuit. The resistor will limit and balance the driving current which flows through every parallel circuits.

2. Electric Static Discharge (ESD) Protection



All kinds of LED materials, such as GaP, AlGaAs, AlInGaP, GaN, or InGaN chips, are STATIC SENSITIVE device. ESD protection or surge voltages shall be considered and taken care in the initial design stage, and whole production process.

The following protection is recommended:

- (1) A wrist band or an anti-electrostatic glove shall be used when handling the LEDs
- (2) All devices, equipment and machinery must be properly grounded

If LED is damaged by ESD or surge voltage, damaged LED may show some unusual characteristics. It may appear leakage current, and LED does not emit at low current.

And when using microscope to inspect damaged LED chip at low driving current, it may have some black dots within the emitting area.

PART NO : EOZ-ZAWNPD0-EG

Spec No.	Date	Page	Ver.
A-Z-045-00	2008/9/10	9/11	A-00

3. Lead Forming

The leads should not be bent at the point of 3mm or below 3mm from the base of the epoxy bulb while forming the leads. It's recommended to cut or form the lead by tooling made rather than by hand operation.

Do not apply any bending stress to the base of the lead, and don't cause any stress after mounting the LED lamp on PCB. The stress to the base may damage the LED's characteristics, or cause deterioration of the epoxy resin. This will hurt and degrade the LEDs.

4. Storage

It's recommended to store the products in the following conditions:

(1) Shelf life in sealed bag: 12 months at $T_A < 40^\circ\text{C}$ and Hum. < 30%RH.

(2) After the package bag is opened and kept in the following environment, the LED products should be used completely as soon as possible:

Humidity (Hum.) : 60%RH Max.

Temperature (T_A) : $5^\circ\text{C} \sim 30^\circ\text{C}$ ($41^\circ\text{F} \sim 86^\circ\text{F}$)

Assembly duration : within 72 hours, after bag is opened.

If the some of LED are not used, they need to be kept at Hum. $\leq 20\%$ RH in zip-locked sealed bags.

Although the leads of LED lamp is plated with pure tin to protect leads from corrosion, devices should be subjected to wave soldering, or equivalent process as soon as possible, after the bag is opened.

Please avoid rapid transitions in ambient temperature, especially in high humidity environment where condensation can occur.

5. Soldering

Soldering heat may damage the LED. Careful attention should be paid during soldering process and PCB assembly. In order to eliminate the stress of heat shock, please solder the LEDs no close than 3mm from the base of the epoxy bulb.

Spec No.	Date	Page	Ver.
A-Z-045-00	2008/9/10	10/11	A-00

PART NO : EOZ-ZAWNPD0-EG

Recommended soldering condition:

	Wave Soldering	Manual Solder Dipping	Hand soldering by iron
Pre-heat Temperature	105°C Max.	-	
Pre-heat Time	30sec Max.	-	
Peak Temperature	250°C Max.	260°C Max.	350°C Max.
Dwell Time	3sec Max.	5sec Max.	3sec Max.

Never take next process until the component is cooled down to room temperature after soldering. It's banned to load any stress on the resin during soldering. If it's necessary to clamp the LED bulbs to help soldering, it is important to minimize the mechanical stress on the LEDs.

The manual soldering process is not recommended for quality consideration. When it is absolutely necessary, the LEDs may be mounted in this fashion but the user will assume responsibility for any problems.

6. Cleaning

An alcohol-based solvent such as isopropyl alcohol (IPA) is recommended to clean the LED bulbs, after soldering process, if cleaning is necessary. Before cleaning, a pre-test should be done to confirm whether any damage to the LEDs will occur.

It is not recommended to use unspecified chemical liquids as cleaning material for cleaning the LED. It's also not recommended to use ultrasonic power to clean the LED device. The chemical and ultrasonic power could harm the LED devices.

7. Others

- (1) The light output of LED might injure human eyes, directly look at the LED without protection is prohibited.
- (2) LED lamp is very sensitive to heat. Thermal design of the end product will decide the performance of LED lamps. It's necessary to avoid intense heat generation and operate within the maximum ratings given in this specification.
- (3) Every piece of LED will be sorted and LEDs with the same binning grade will be taped into the same reel or put into the same bag. It is recommended to use the same bin-grade LED to assembly the unit module. This will ensure the LED unit module with good uniformity of brightness, hue, and so on.

PART NO : EOZ-ZAWNPD0-EG

Spec No.	Date	Page	Ver.
A-Z-045-00	2008/9/10	11/11	A-00

Terms and Conditions

1. EOI warrants all sold LEDs which conform to the specifications approved by the customers.
2. Any LED supplied by EOI is found not conform to the specifications that both parties agreed upon, customer should claim within 90days of receipt. EOI will repair or replace the LEDs at EOI's option.
3. EOI will not hold any responsibility for the failed LEDs, which are caused by mishandling or misusing the LEDs exceeding the operating conditions that EOI suggested.
4. EOI's LED products are designed and manufactured for general electronic equipment (such as household appliances, communication equipment, office equipment, electronic instrumentation and so on). If customer's application requires exceptional quality or reliability, which might concern human safety, it is recommended to consult with EOI in advance.
5. All the information published is considered to be reliable. However, EOI does not assume any liability arising out of the application or use of any product described herein. EOI's liability for defective LED lamps shall only be limited to replacement, in no event shall EOI be liable for consequential damages or loss.
6. EOI and customer shall both confirm the specifications herein, and all quality related matters will base on the specifications both parties agreed upon.
7. Any modification of the design or manufacturing process taken place, which will affect the characteristics, performance or reliability of LED, customer's approval will be required.
8. This specification approval sheet is an agreement of shipment specification. Please sign it back and keep the copies in two parties. If customers don't sign it back, it is regarded as completely agree with the terms and conditions and also approve of this approval sheet.

Company Information

Headquarters

Excellence Opto. Inc.

5F, No. 1, Creation Road II, Hsinchu Science Park, Hsinchu, Taiwan 30077, R.O.C.
Tel : 886-3-5679000 Fax: 886-3-5679999
E-mail: Service@eoi.com.tw
http://www.eoi.com.tw



U.S. Office

Excellence Opto. Inc.

1400 W. Lambert Road, Suite B, Brea, CA 92821, U.S.A.
Tel: 1-562-694-1246 Fax: 1-562-691-3087
E-mail: Sales@eoius.com

China Factory

Lianxinfeng Opto. Co., Ltd. (LXF)

Bldg. No. 15, Tongfuyu Industrial Park, Longhua, Shenzhen, P.R.C.
Tel : 86-755-2814-0029 Fax: 86-755-2814-0027