



Q-RACK

19" Wall mounting rack

RETEX
Efficient IT Solutions

E Armarios 19" para el soporte mural de instalaciones de redes, telecomunicaciones y equipos electrónicos.
Diseñado según normas IEC 60 297-2, DIN 41494 partes 1 y 7, ANSI / EIA-310-D y UNE 20 539-2.

Nuevo concepto de rack mural, listo para su instalación:

- Puerta frontal de vidrio de seguridad, espesor 4 mm, con marco integrado y cierre por llave.
- Lateral desmontable (1) con cierres rápidos de 1/4 de vuelta.
- Tapas sup./inf. con mecanizados para fijación de unidad de ventilación modulares (2 ventiladores con/sin termostato) o directamente ventiladores de 105x105 mm
- Entradas de cable pre-mecanizadas superior inferior, con posibilidad de montaje de cepillos para el paso de cables o tapa de entrada de cables en ABS fácilmente mecanizable.
- 2 perfiles 19" de acero, espesor 1.5 mm, desplazables en profundidad en intervalos de 20 mm e indicadores de posición U's.



EN 19" wall mounted cabinets. For cabling, telecommunications, IT and industrial installations.
Designed in accordance with IEC60 297-2, DIN 41944 part 1 and 7, ANSI/EIA-310 and UNE 20 539-2.

New concept of wall cabinet. Delivered fully assembled ready to be installed:

- Front door with integrated printed frame and tempered clear safety glass
- Easily removable side panel (1) with 2x 1/4 turn locks
- Newly designed top and base panels, with ventilated areas for installing modular fan trays or directly fans of 105 x105 mm
- New cable entry options in top and base, with optional plastic blanking covers or optional brush strip fittings.



F Coffrets muraux 19", pour installations de câblage, Télécommunications, IT et installations industrielles.
Conception selon les normes IEC 60 297-2, DIN 41944 part. 1 & 7, ANSI/EIA-310 et UNE 20 359-2.

Nouveau concept de coffret mural livré monté, prêt à l'emploi:

- Porte frontale en verre trempé de 4 mm d'épaisseur, cadre en sérigraphie et fermeture à clef.
- 1x Latéral démontable para vis rapides ¼ de tour en ABS.
- Panneaux supérieur et inférieur usinés avec zones de ventilation pour le montage d'unité de ventilation modulaire, ou bien directement des ventilateurs de 120x80 mm.
- Nouvelles entrées de câblage pré-usinées en supérieur et inférieur permettant le montage de panneaux obturateurs en ABS ou bien de brosse passe-câbles.
- 2x Profilés intérieurs 19", profondeur variable par pas de 20 mm et marquage des "U".
- Connexions à la terre dans tous les côtés du Cubick.



Tapa posterior opcional
Rear door in option

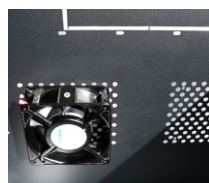
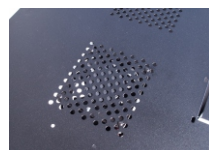

Code	19"	U / HE	A	b	c
32330006	*	6	599	450	360
32330009	*	9	599	450	493
32330112	*	12	599	500	626
32330115	*	15	599	500	760

AMPLIA GAMA DE ACCESORIOS (opcional)
WIDE RANGE OF ACCESSORIES (optional)

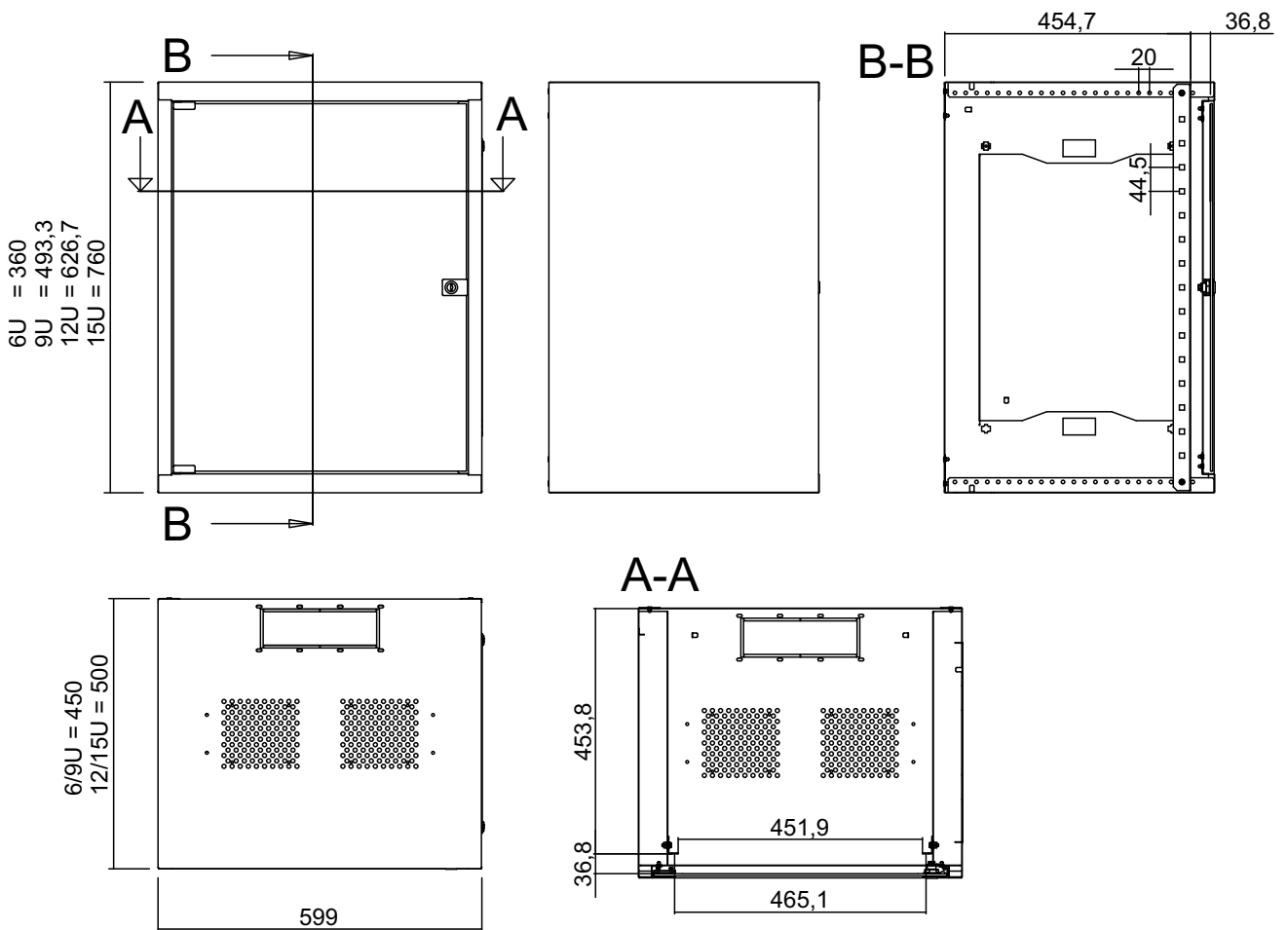
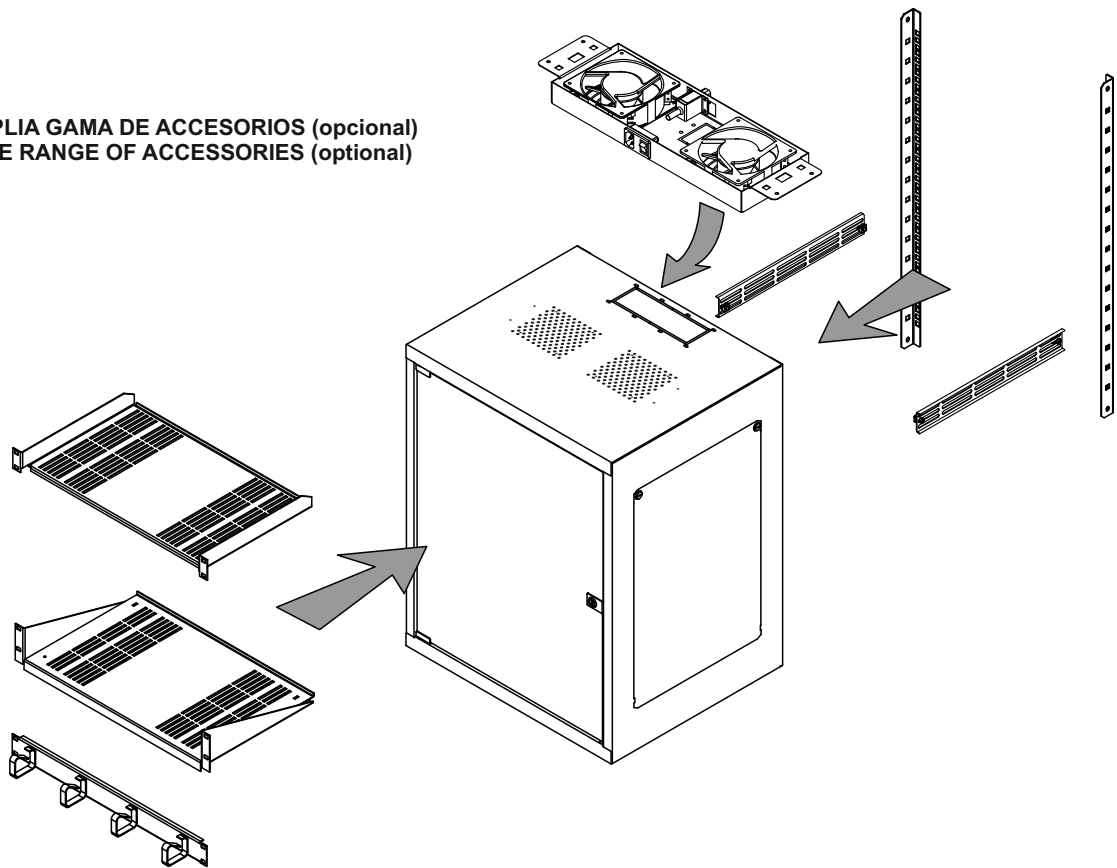

The best way to predict the future is to invent it. [Alan Kay]



RETEX

Avda. Tecnología, 35
08840 VILADECANS
Barcelona - Spain
www.retex.es
email: info@retex.es
Tel +34 93 264 98 50
Fax +34 93 659 23 68

6 Stanton Close
Finedon Road Ind State
Wellingborough, Northants
NN8 4HN
United Kingdom
www.retexuk.com
Tel. +44 (0) 1933 234448
Fax +44 (0) 1933 234449

Pereira de la Luz, 1080
11300 MONTEVIDEO
Uruguay
www.retextelecom.com
email: retex@retextelecom.com
Tel. +5982 6223408
Fax +5982 2045797

D-220 Ansa Industrial Estate Road
Saki-Vihar Road, Andheri East
MUMBAI 400072
India
www.retex.co.in
email: retex@retex.co.in
Tel: +9122 28575934



RETEX colabora con www.run4help.org
RETEX collaborates with www.run4help.org
RETEX collabore avec www.run4help.org

Q-raek catalogue. 05/2015
Trolley Logística, S.L. (RETEX) se reserva el derecho a introducir modificaciones en la información de este catálogo sin previo aviso. Trolley Logística (RETEX) reserves the right to change the information included in this catalogue without prior notice.
Trolley Logística, S.L. (RETEX) se réserve le droit de procéder a des modifications des information du present catalogue sans preavis.